



These hydraulically powered tools are designed to effectively install HUCK's two-piece PowerBolts™. When driven by one of the company's POWERIG® Hydraulic Power Systems, these PowerDrive™ tools combine speed, ease of use and reliability in applications ranging from truck frame to rail crossing fastening.

- |                           |  |
|---------------------------|--|
| <b>PowerDrive™ 506</b>    | A front ejection tool, designed for installation of larger fasteners to 7/8" diameter                |
| <b>PowerDrive™ 507</b>    | A longer stroke model designed to install fasteners of up to 1" diameter in a production environment |
| <b>PowerDrive™ 585</b>    | Installs up to 3/4" in a high volume production environment  |
| <b>PowerDrive™ 586</b>    | A longer stroke production tool, for installation of larger fasteners up to 3/4" diameter            |
| <b>PowerDrive™ 5901</b>   | Same design and capabilities as the FE5901. Features rear ejection of pintail.                       |
| <b>PowerDrive™ FE5901</b> | A front ejection tool, designed for installation of larger fasteners to 1/2" diameter                |
| <b>PowerDrive™ 12142</b>  | A heavy duty tool designed for installation of 1-3/8" diameter PowerBolts™                           |



Previous  
Screen

## PowerDrive 506

### Hydraulic Powered Installation Tool

#### Specifications

*Weight:*

33 lbs.

*Stroke:*

2.0 in.

*Pressure:*

Pull-5,400 psi

Return-2,800 psi

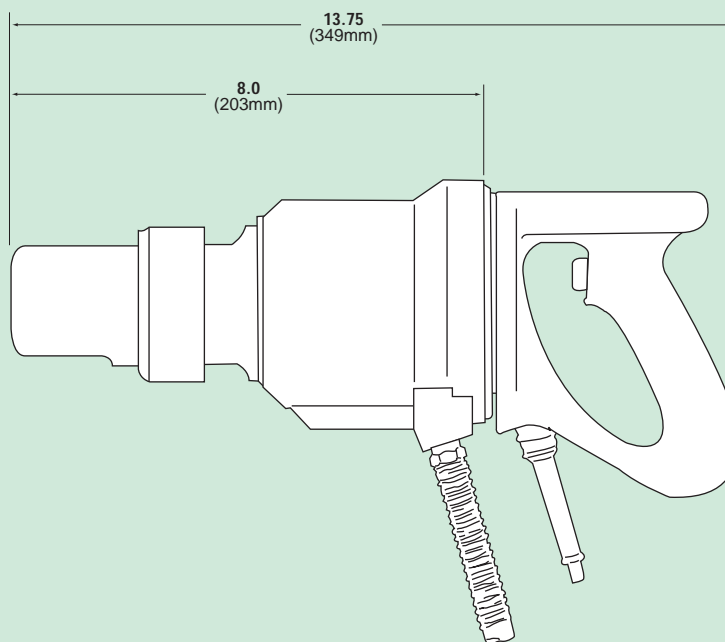

Table of  
Contents

PowerDrive 506

#### Compatible Fastener

Type	Diameter	Nose Assembly
C50L	7/8	99-5014



The PowerDrive 506 is a heavy-duty tool sized for the installation of a number of larger C50L LockBolt fasteners, up to 7/8" in diameter. This rugged tool provides high-speed installation in a wide range of production applications.

POWERIG



Previous  
Screen

## PowerDrive 507

### Hydraulic Powered Installation Tool

#### Specifications

*Weight:*

43 lbs.

*Stroke:*

2.5 in.

*Pressure:*

Pull-5,400 psi

Return-2,800 psi

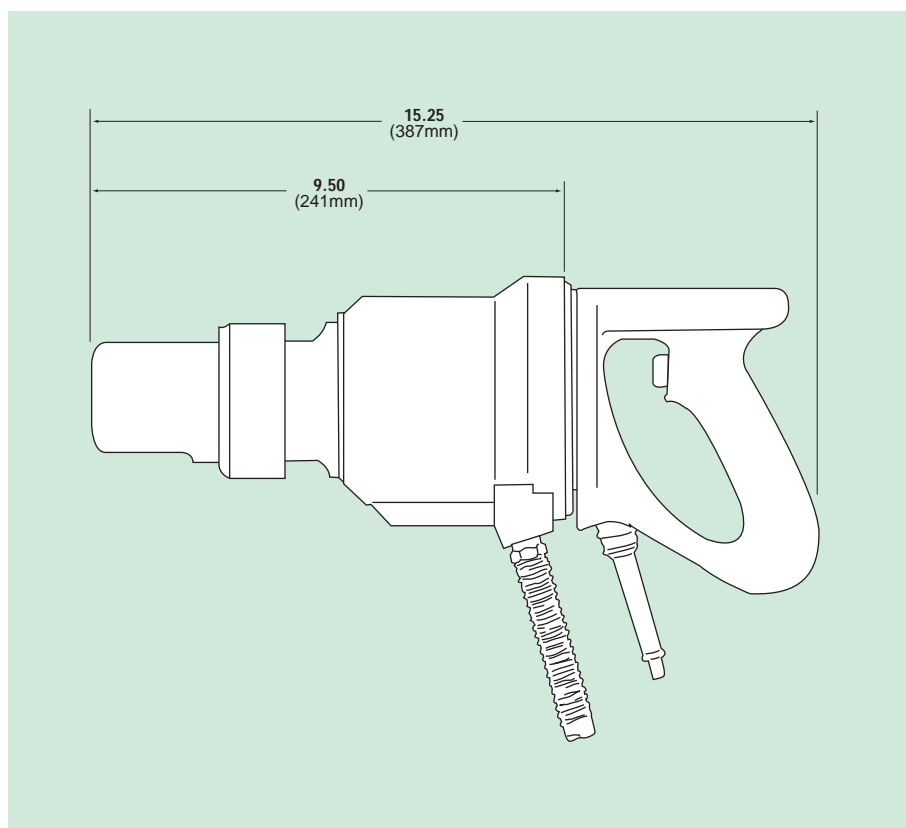

#### Compatible Fastener

Type	Diameter	Nose Assembly
C50L	1	99-5016
	1 1/8	99-5019
HUCKFIT	20mm	99-5414
	5/8	99-5414



The PowerDrive 507 is a heavy-duty tool sized for the installation of a number of larger C50L LockBolt fasteners, up to 1-1/8" in diameter. This rugged tool provides high-speed installation in a wide range of production applications.

Table of  
Contents

PowerDrive 507

POWERIG



Previous  
Screen

## PowerDrive 585

### Hydraulic Powered Installation Tool

#### Specifications

*Weight:*

19 lbs.

*Stroke:*

1.60 in.

*Pressure:*

Pull-5,400 psi

Return-2,800 psi

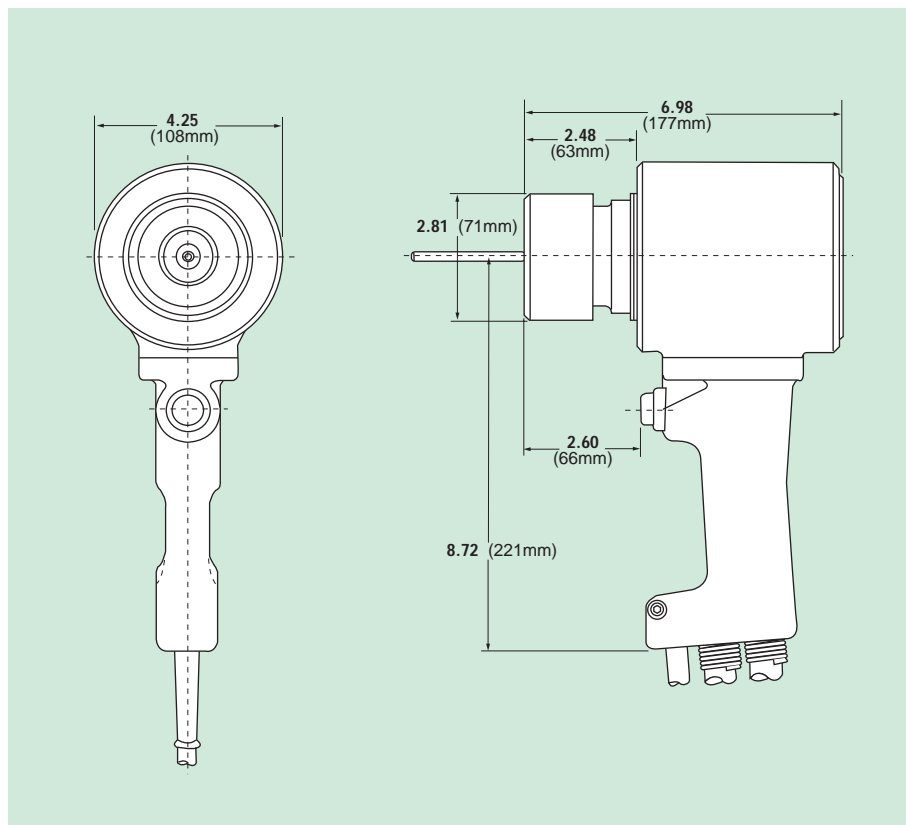

#### Compatible Fastener

Type	Diameter	Nose Assembly
BOM	5/8	99-5102
C50L	5/8	99-5008
	3/4	99-5010
HUCKFIT	3/4	99-5303
HP8	5/8	99-5301
	3/4	99-5303



The PowerDrive 585 is sized for the high-speed installation of HUCK's larger fasteners. The tool features an in-line piston which extends seal life. The PowerDrive 585 has only one moving part, which further minimizes maintenance.

Table of  
Contents

PowerDrive 585

POWERIG



Previous  
Screen

## PowerDrive 586

### Hydraulic Powered Installation Tool

#### Specifications

*Weight:*

21.5 lbs.

*Stroke:*

2.0 in.

*Pressure:*

Pull-5,400 psi

Return-2,800 psi

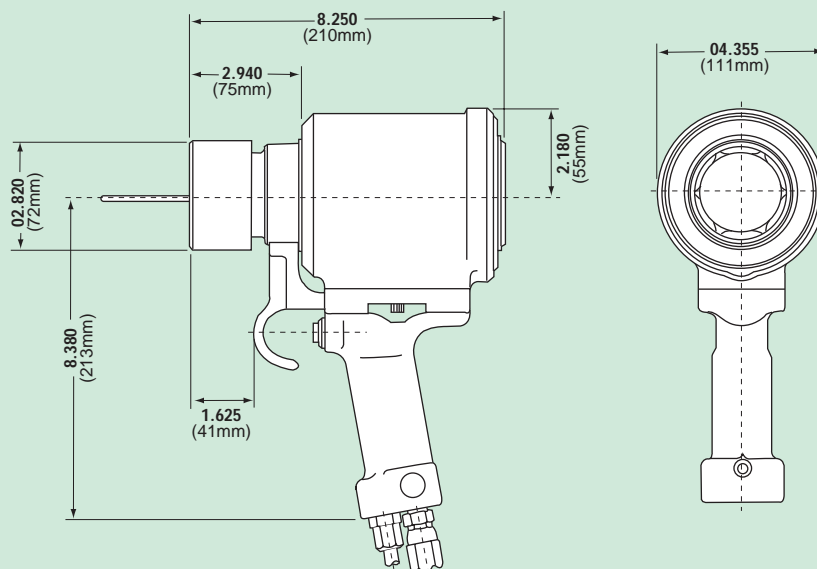

Table of  
Contents

PowerDrive 586

#### Compatible Fastener

Type	Diameter	Nose Assembly
BOM	5/8	99-5102
	3/4	99-5103
C50L	5/8	99-5008
	3/4	99-5010
HUCKFIT	16mm	99-5300
	3/4	99-5303
HP8	5/8	99-5301
	3/4	99-5303



The PowerDrive 586 tool is sized for the high-speed installation of HUCK's larger fasteners. Although similar in design to the PowerDrive 585 tool, the 586 provides a slightly larger production capacity. The tool features an in-line piston which extends seal life. The PowerDrive 586 features the reliability with a single moving part.

POWERIG



Previous  
Screen

## PowerDrive 5901

### Hydraulic Powered Installation Tool

#### Specifications

*Weight:*  
13 lbs.

*Stroke:*  
1.25 in.

*Pressure:*  
Pull-5,700 psi  
Return-2,800 psi

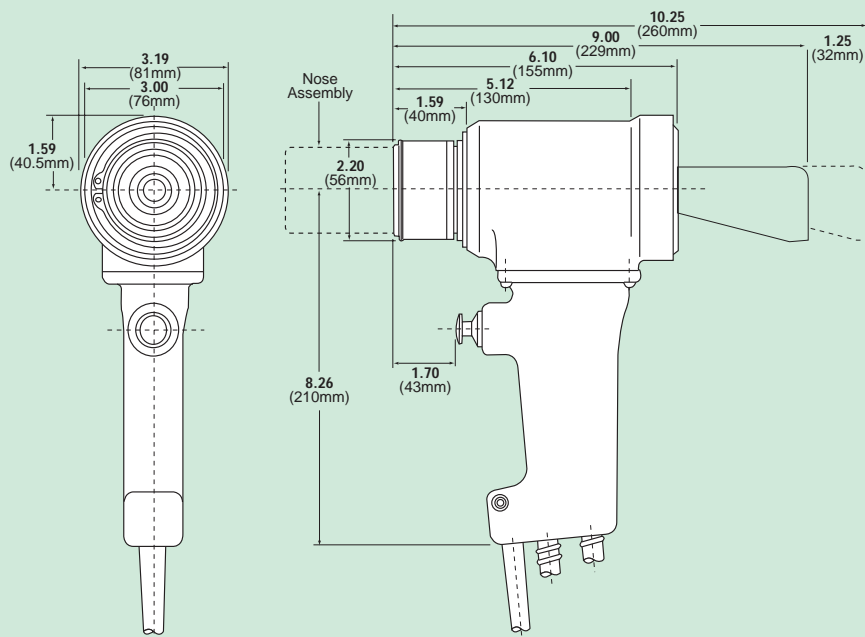

#### Compatible Fastener

Type	Diameter	Nose Assembly
BOM	1/2	99-5100
C50L	1/2	99-5002
MAGNA-GRIP	3/8	H99-1492
HP8	1/2	99-5300
HUCK-FIT	12mm	99-5404 99-5406
	1/2	99-5404



The PowerDrive 5901 tool is suited for heavy duty installation of lockbolts and large blind bolts. This rugged tool features an in-line piston which extends seal life. Maintenance is minimized by the tool's design which requires a single moving part.

Table of  
Contents

PowerDrive 5901

POWERIG



Previous  
Screen

## PowerDrive FE5901

### Hydraulic Powered Installation Tool

#### Specifications

*Weight:*  
13 lbs.

*Stroke:*  
1.25 in.

*Pressure:*  
Pull-5,700 psi  
Return-2,800 psi

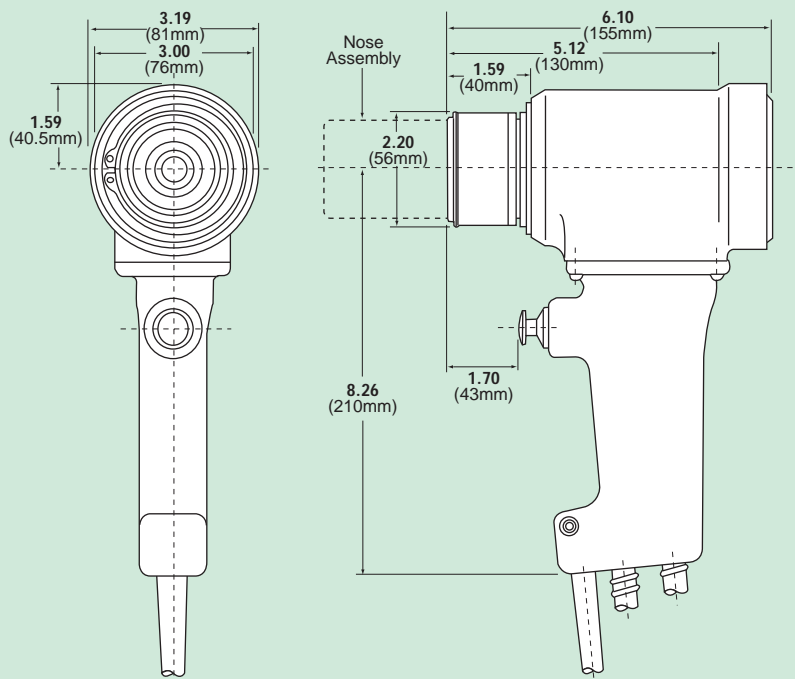

Table of  
Contents

PowerDrive FE5901

#### Compatible Fastener

Type	Diameter	Nose Assembly
BOM	1/2	99-5100
C50L	1/2	99-5000
MAGNA-GRIP	3/8	99-1492
HP8	1/2	99-5300



The PowerDrive FE5901 tool is suited for heavy duty installation of lockbolts and large blind bolts. This rugged tool features an in-line piston which extends seal life. Maintenance is minimized by the tool's design which requires a single moving part. Special front pintail ejection system ensures operation safety.

POWERIG



