

Alcoa
Fastening
Systems



Huck BobTail® System

The Next-Generation
LockBolt for Heavy-Duty
Applications





Record installation times and precision engineered tooling make BobTail® the most advanced fastening system in the industry.

Developed to meet the unique challenges of heavy assembly applications in the truck and rail industries, the BobTail System is built for high-performance and reliability. Available in a wide range of sizes and grades, BobTail fasteners and tooling are precisely matched to the application, offering lower installed costs and increased user safety for both assembly and repair.

Two-second installation.

The BobTail System delivers a lightning-quick, two-second installation cycle time for unmatched productivity. And only a quick, visual inspection is needed to ensure a secure fit.

Lightweight, technologically advanced tooling.

Because of Alcoa Fastening Systems' patented Swageforward® technology, BobTail tooling makes the installation process quicker and easier. More compact and lighter weight, BobTail tooling offers greater operator flexibility and extended reach into difficult areas.

Safe and silent performance.

The precision engineered BobTail fastener is installed without a pin-break, contributing directly to noise reduction on the shop floor, and subsequently, worker hearing safety. Instances of foreign object damage (FOD) and loose pintail injuries are eliminated. And because BobTail tooling features a smooth, shock-free installation sequence, jolts to the operator are eliminated, and overall safety is increased.

Cost-efficient operation.

Smooth-operating BobTail tooling directly contributes to longer tool and component life, while allowing extended tool maintenance cycles. As a result, costs for parts and overall support are reduced, while system uptime is increased.

Pintailless design means 2 second installations, no noise and no waste. Without a break-away pintail, there is no initiation point for corrosion, eliminating secondary operations on the fastener.

Collar material swaged into the lockgrooves forms a permanent, vibration-proof connection that ensures the integrity of the joint.

Low-swage technology allows for faster, lighter tooling with parts that last longer.

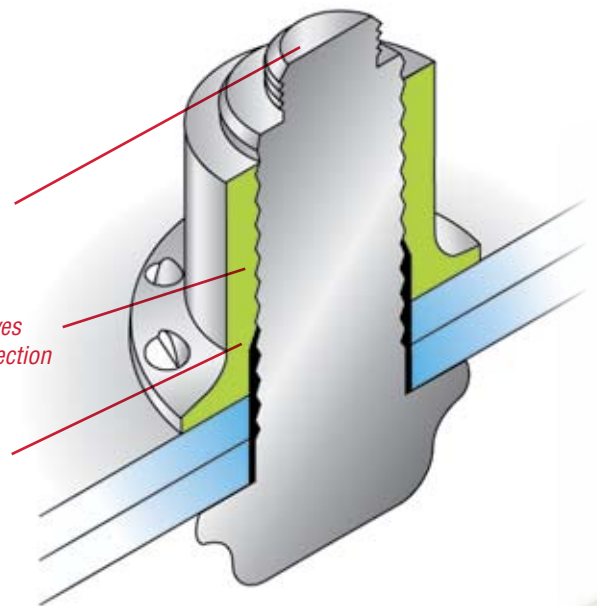

Huck BobTail® System

Installation Sequence

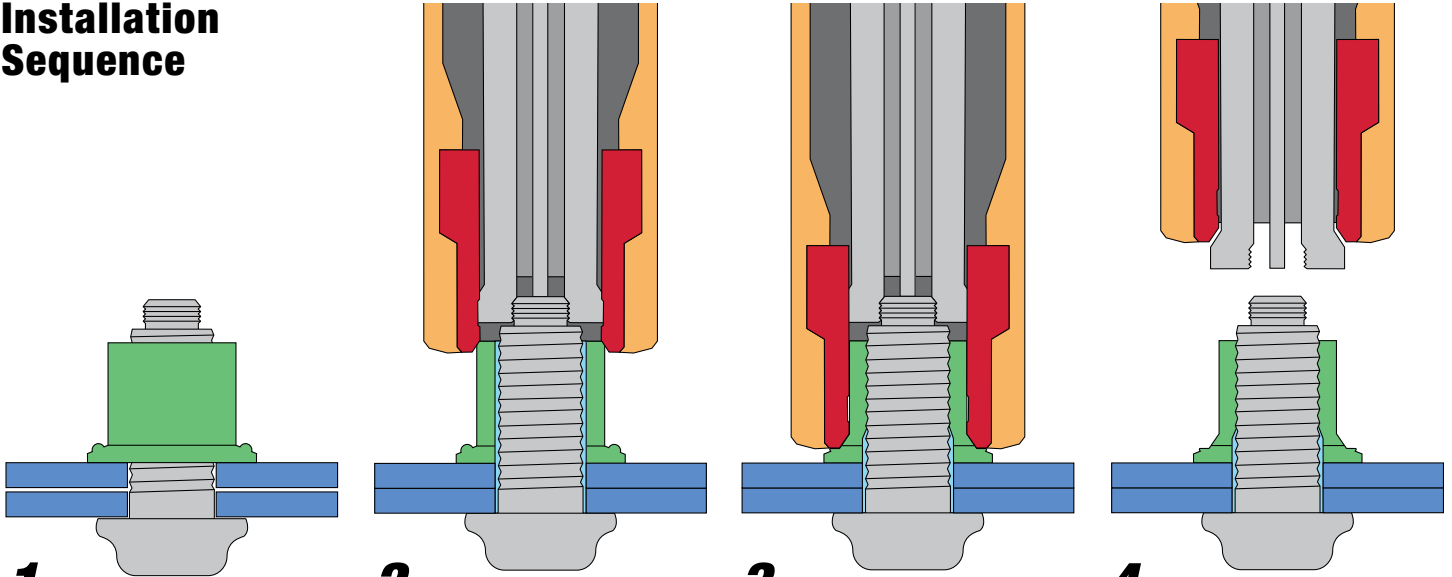

1

The pin is inserted into the prepared hole and the collar is spun onto the pin down to the sheet line.

2

The installation tool is applied to annular pull grooves. When the tool is activated, pullers in the nose assembly draw the pin into the tool, causing the swaging anvil to press on the collar, creating a standoff load that draws up any sheet gap.

3

At a predetermined force, the anvil begins to swage the collar into the pin's lockgrooves. Continued swaging elongates the collar and pin developing precise clamp.

4

When swaging of the collar into the pin lockgrooves is complete, the tool ejects the fastener and releases the puller to complete the installation sequence.

Tool Specifications

Model	Weight lbs.	Length in. (cm)	Height in. (cm)	Width in. (cm)
Model BTT20SF	11.5	16.61 (6.54)	23.19 (9.13)	7.3 (2.88)
Model BTT25 (12mm nose)	10.5	34.77 (13.69)	6.32 (2.49)	—
Model BTT25 (14mm nose)	10.5	34.95 (13.76)	6.32 (2.49)	—
Model BTT35	14.0	32.11 (12.64)	6.03 (2.37)	—
Model BTT35R	16.0	50.65 (19.94)	6.99 (2.75)	—
Model BTT57 (20mm nose)	26.0	48.01 (18.90)	8.99 (3.54)	—
Model BTT57 (22mm nose)	28.5	48.01 (18.90)	8.99 (3.54)	—



Model BTT20SF



Model BTT35

HUCK**For the Long Haul™**

The Benefits of Huck Fastening Systems

Huck fastening systems deliver a number of important benefits, making them the worldwide leader.

- Easy to use – consistent accuracy with little operator training required
- High productivity – reducing installation time by 25% to 50%
- Reduced QC procedures – a visual inspection is sufficient to verify a correct installation
- Consistent high-clamp performance – typically much higher than with conventional fasteners
- Durability – extremely high clamp force retention, with 10% to 20% greater fatigue life than conventional threaded fasteners

Alcoa Fastening Systems Commercial Products: A Global Organization

Alcoa Fastening Systems (AFS) maintains company offices in the United States and Canada, with offices in many other countries. Authorized AFS fastener distributors are also located in many of the world's industrial centers, where they provide a ready source of AFS fasteners, installation tools, tool parts, and application assistance.

Americas

Industrial Fastener Division

8001 Imperial Drive
Waco, TX 76712, USA
P.O. Box 8117
Waco, TX 76714-8117, USA
Tel: 800 388 4825
Fax: 800 798 4825

Installation Tool Division

1 Corporate Drive
Kingston, NY 12401, USA
Tel: 800 278 4825
Fax: 845 334 7333

Indianapolis Distribution

5436 West 78th Street
Indianapolis, IN 46268, USA
Tel: 800 826 2884
Fax: 800 573 2645

California Distribution

1925 North MacArthur Drive
Tracy, CA 95376, USA
Tel: 209 839 3000

Latin America Sales

Avenida Parque Lira
79-402 Tacubaya
MEXICO C P 11850
Tel: 52 55 5515 1776
Fax: 52 55 5277 7564

Mississauga Distribution

6150 Kennedy Road, Unit 10
Mississauga, Ontario L5T-2J4
CANADA
Tel: 905 564 4825
Fax: 905 564 1963

International Locations

India Operations

7th Floor
Meridien Commercial Tower
Raisina Road
New Delhi – 110 001, INDIA
Tel: 00 91 11 23717870 – 75
Fax: 00 91 11 23717876

Japan/Korea Sales

Fuji Bldg #506 Marunouchi 323
Chiyoda-ku, Tokyo 100-0005
JAPAN
Tel: 81 3 3287 1701
Fax: 81 3 3287 1754

Melbourne Operations

20 Stamford Road
Oakleigh, Victoria, 3166
AUSTRALIA
Tel: 61 3 9567 3377
Fax: 61 3 9563 1980

Beijing Sales

Alcoa Asia Pacific Beijing Office
Room 3701, China World Tower 1
1 Jian Guo Men Wai Avenue
Beijing, 100004, CHINA
Tel: 86 10 59215000
Fax: 86 10 59215100

Shanghai Sales

Area A2, 1st Floor
No. 205 TaiGu Road
Waigaoqiao Free Trade Zone
Shanghai, 200131, CHINA
Tel: 86 21 58665080
Fax: 86 21 58681859

Suzhou Sales

58 Yinsheng Road
Shengpu
Suzhou Industrial Park
Suzhou, Jiangsu 215126, CHINA
Tel: 86 512 62863800
Fax: 86 512 62863810

Telford Operations

Unit C, Stafford Park 7
Telford, Shropshire TF3, 3BQ
UNITED KINGDOM
Tel: 44 1952 290011
Fax: 44 1952 290459

Your Authorized Distributor

AF286 0608

© 2008 Alcoa Fastening Systems
www.alcoafasteningssystem.com

For The Long Haul, The Future of Fastening Technology, The Future of Assembly Technology, The Future of Tooling Technology, and Tools of Productivity are service marks of Alcoa Fastening System. AFS provides technical assistance regarding the use and application of both fasteners and tooling.

NOTICE: The information contained in this publication is only for general guidance with regard to properties of the products shown and/or the means for selecting such products, and is not intended to create any warranty, express, implied, or statutory; all warranties are contained only in AFS's written quotations, acknowledgements, and/or purchase orders. It is recommended that the user secure specific, up-to-date data and information regarding each application and/or use of such products.

Alcoa Fastening Systems



One Great ConnectionSM